

INSTRUCTIONS

MODEL AV-143B-PS

0 to $\pm 4V$ IN,

0 to $\pm 20V$ OUT, TO 50 OHMS,

DC-COUPLED LINEAR AMPLIFIER

SERIAL NUMBER: _____

WARRANTY

Avtech Electrosystems Ltd. warrants products of its manufacture to be free from defects in material and workmanship under conditions of normal use. If, within one year after delivery to the original owner, and after prepaid return by the original owner, this Avtech product is found to be defective, Avtech shall at its option repair or replace said defective item. This warranty does not apply to units which have been disassembled, modified or subjected to conditions exceeding the applicable specifications or ratings. This warranty is the extent of the obligation assumed by Avtech with respect to this product and no other warranty or guarantee is either expressed or implied.

TECHNICAL SUPPORT

Phone: 613-226-5772 or 1-800-265-6681

Fax: 613-226-2802 or 1-800-561-1970

E-mail: info@avtechpulse.com

World Wide Web: <http://www.avtechpulse.com>

TABLE OF CONTENTS

WARRANTY	2
TECHNICAL SUPPORT	2
TABLE OF CONTENTS	3
INTRODUCTION	4
SPECIFICATIONS	4
EC DECLARATION OF CONFORMITY	5
INSTALLATION	6
VISUAL CHECK	6
LINE VOLTAGE SELECTION	6
CONNECTION TO THE POWER SUPPLY	7
POWER RATINGS	8
ENVIRONMENTAL CONDITIONS	8
FUSES	9
AC FUSE REPLACEMENT	9
DC FUSE REPLACEMENT	10
FUSE RATINGS	10
FRONT PANEL CONTROLS	11
REAR PANEL CONTROLS	12
GENERAL INFORMATION	13
BASIC OPERATION	13
OPERATIONAL CHECK	14
USAGE PRECAUTIONS	15
INTERNAL ADJUSTMENTS	15
MECHANICAL INFORMATION	16
TOP COVER REMOVAL	16
RACK MOUNTING	16
ELECTROMAGNETIC INTERFERENCE	16
MAINTENANCE	17
REGULAR MAINTENANCE	17
CLEANING	17
PERFORMANCE CHECK SHEET	18

INTRODUCTION

The Model AV-143B-PS DC-coupled linear amplifier has a gain (V_{OUT}/V_{IN}) of +5. The input may range from 0 to $\pm 4V$. The input impedance is $1\text{ k}\Omega$. The corresponding output range is 0 to $\pm 20V$, into load impedances of 50Ω or greater.

The output rise and fall times are 50 ns or less.

This instrument is intended for use in research and development laboratories.

SPECIFICATIONS

Model:	AV-143B-PS
Output amplitude: (max) ($R_L = 50\ \Omega$)	$\pm 20V$
Voltage Gain:	+5 (non-inverting)
Rise, fall time:	$\leq 50\text{ ns}$
Input impedance ¹ :	$1\text{ k}\Omega$
Output impedance:	2Ω
Bandwidth:	DC-10 MHz
Power out: (max)	4 Watts
Overshoot:	$\leq 6\%$
Prime power ² :	115/230 Volts, 50 - 60 Hz
Connectors:	BNC
Dimensions ² :	100 x 215 x 375 mm (3.9" x 8.5" x 14.8")

EC DECLARATION OF CONFORMITY

We

Avtech Electrosystems Ltd.
P.O. Box 5120, LCD Merivale
Ottawa, Ontario
Canada K2C 3H4

declare that this pulse generator meets the intent of Directive 89/336/EEC for Electromagnetic Compatibility. Compliance pertains to the following specifications as listed in the official Journal of the European Communities:

EN 50081-1 Emission

EN 50082-1 Immunity

and that this pulse generator meets the intent of the Low Voltage Directive 72/23/EEC as amended by 93/68/EEC. Compliance pertains to the following specifications as listed in the official Journal of the European Communities:

EN 61010-1:2001 Safety requirements for electrical equipment for measurement, control, and laboratory use



INSTALLATION

VISUAL CHECK

After unpacking the instrument, examine to ensure that it has not been damaged in shipment. Visually inspect all connectors, knobs, and handles. Confirm that a power cord is with the instrument. If the instrument has been damaged, file a claim immediately with the company that transported the instrument.

LINE VOLTAGE SELECTION

Examine the rear of the instrument. There will be a power-entry module consisting of a male power receptacle, the main power switch, and a fuse holder / voltage selector. Confirm that the voltage selector is in the correct orientation. For AC line voltages of 115V \pm 10%, 50 - 60 Hz, the power selector card should be installed so that the "115" marking is visible from the rear of the instrument. For AC line voltages of 230V \pm 10%, 50 - 60 Hz, the power selector card should be installed so that the "230" marking is visible from the rear of the instrument. The two possible settings are shown below:

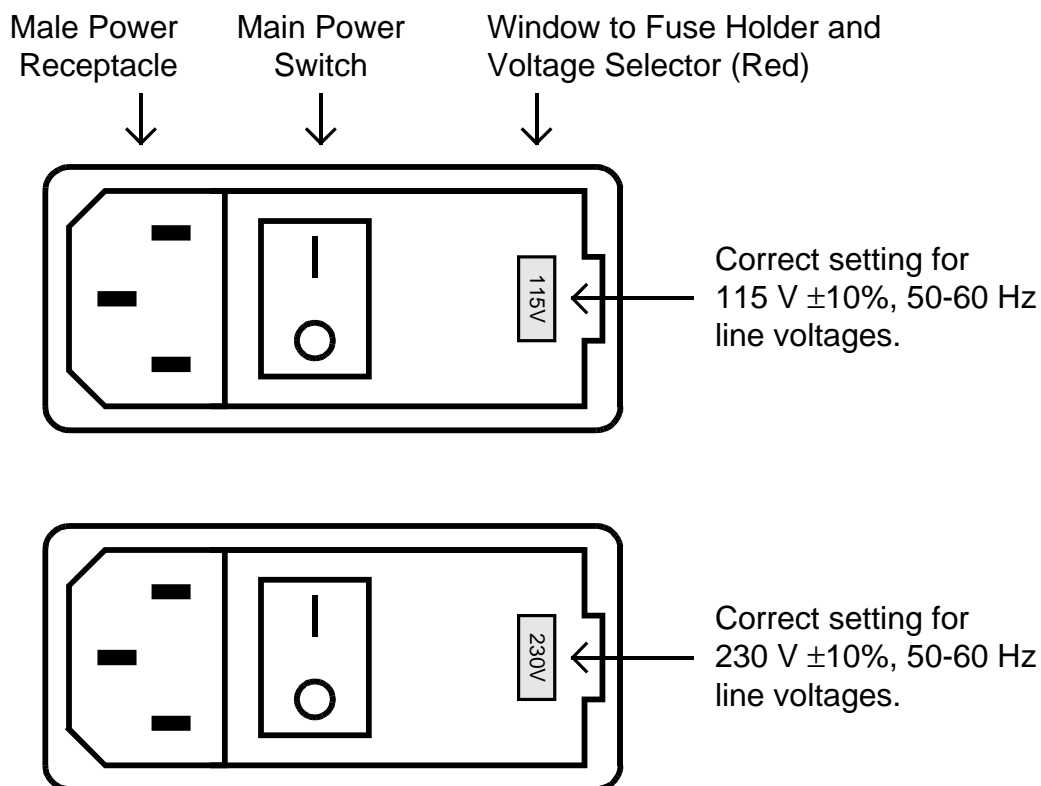

If the voltage selector is not set for to proper voltage, use a small flat-head screwdriver to pry open the voltage selector panel, as shown below:

Fuse Holder and Voltage Selector Panel.
The panel is hinged on the left. Pry open
with a flat screwdriver from the right.

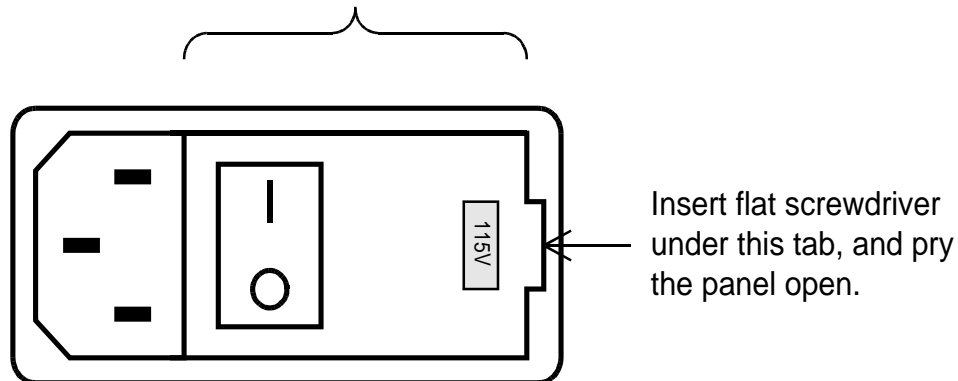

Fuse Holder and Voltage Selector.
After opening the panel, the red plastic
fuse holder and voltage selector will be
visible.

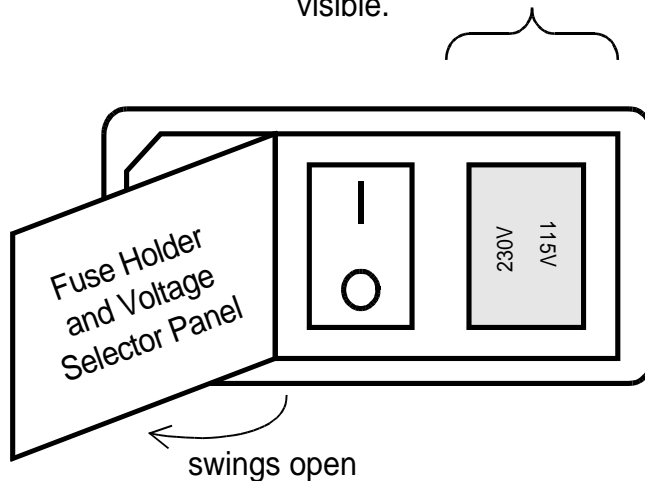

Once the panel is open, the red fuse holder / voltage selector should be visible. To change the voltage setting, pull out the red fuse holder / voltage selector and rotate it so that the proper voltage marking will shown through the panel window. Re-install the red fuse holder / voltage selector, and close the panel.

CONNECTION TO THE POWER SUPPLY

An IEC-320 three-pronged recessed male socket is provided on the back panel for AC power connection to the instrument. One end of the detachable power cord that is supplied with the instrument plugs into this socket. The other end of the detachable power cord plugs into the local mains supply. Use only the cable supplied with the instrument. The mains supply must be earthed, and the cable used to connect the

instrument to the mains supply must provide an earth connection. (The supplied cable does this.)

POWER RATINGS

This instrument is intended to operate from 115 / 230 V \pm 10%, 50-60 Hz. The maximum power consumption is 57W. This instrument is an "Installation Category II" instrument, intended for operation from a normal single-phase supply.

ENVIRONMENTAL CONDITIONS

This instrument is intended for use under the following conditions:

- a) indoor use;
- b) altitude up to 2 000 m;
- c) temperature 5 °C to 40 °C;
- d) maximum relative humidity 80 % for temperatures up to 31 °C decreasing linearly to 50 % relative humidity at 40 °C;
- e) Mains supply voltage fluctuations up to \pm 10 % of the nominal voltage;
- f) no pollution or only dry, non-conductive pollution.

FUSES

This instrument contains four fuses. All are accessible from the rear-panel. Two protect the AC prime power input, and two protect the internal DC power supplies. The locations of the fuses on the rear panel are shown in the figure below:

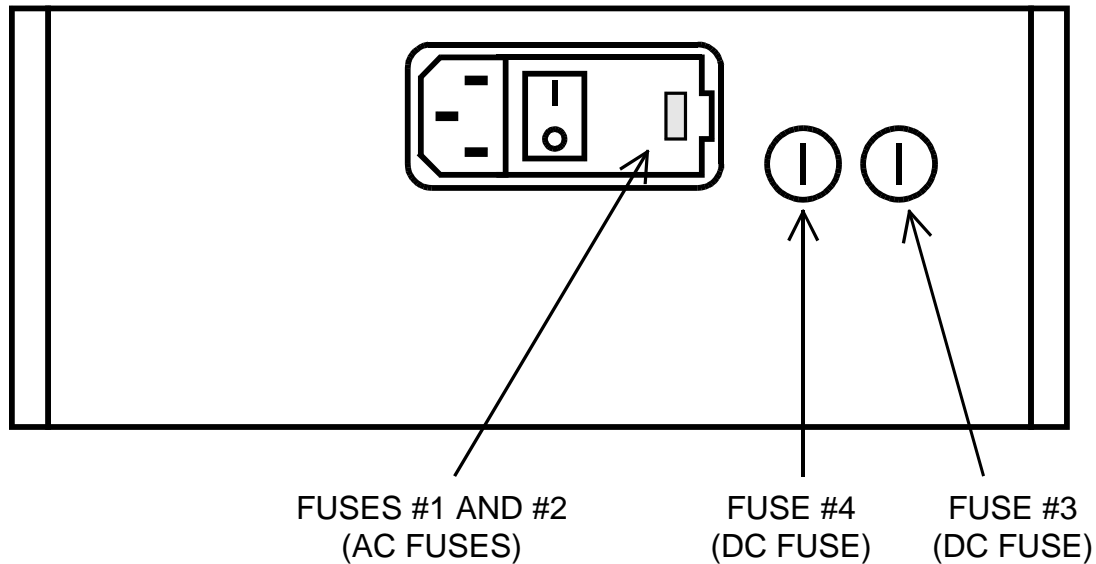

AC FUSE REPLACEMENT

The red fuse holder / voltage selector described in the previous section contains two fuses. One protects the AC “Line” input, and one protects the AC “Neutral” input. To replace the AC fuses, pull out the red fuse holder / voltage selector (as described in the previous section). The location of the two identical 5 mm x 20 mm fuses is shown below:

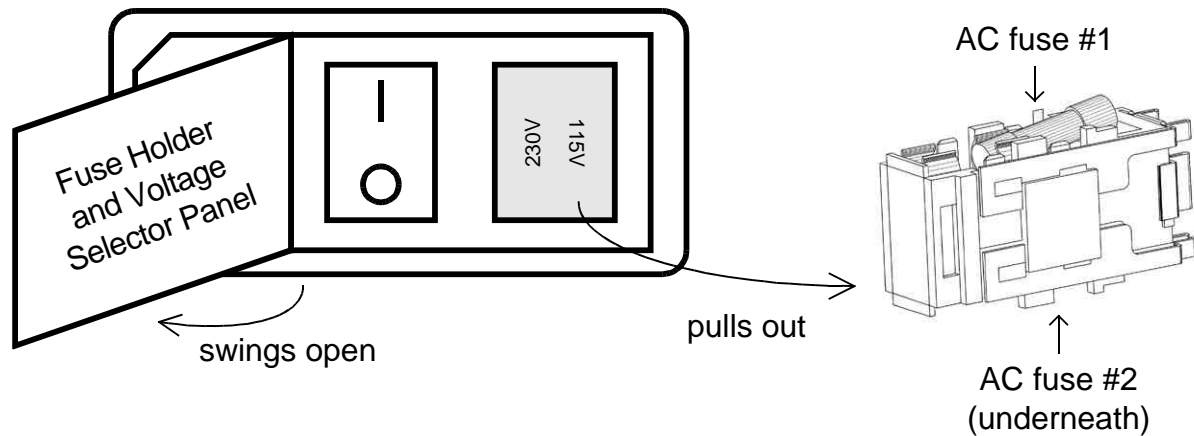

DC FUSE REPLACEMENT

The DC fuses may be replaced by inserting the tip of a flat-head screwdriver into the fuseholder slot, and rotating the slot counter-clockwise. The fuse and its carrier will then pop out.

FUSE RATINGS

The following table lists the required fuses:

Fuses	Mains Voltage	Rating	Case Size	Manufacturer's Part Number (Wickmann)	Distributor's Part Number (Digi-Key)
#1, #2 (AC)	115 V	0.5A, 250V, Time-Delay	5 x 20 mm	1950500000	WK5041-ND
	230 V	0.25A, 250V, Time-Delay	5 x 20 mm	1950250000	WK5035-ND
#3 (DC)	115/230V	1.0A, 250V, Time-Delay	5 x 20 mm	1951100000	WK5048-ND
#4 (DC)	115/230V	1.0A, 250V, Time-Delay	5 x 20 mm	1951100000	WK5048-ND

The fuse manufacturer is Wickmann (<http://www.wickmann.com/>).

Replacement fuses may be easily obtained from Digi-Key (<http://www.digikey.com/>) and other distributors.

FRONT PANEL CONTROLS

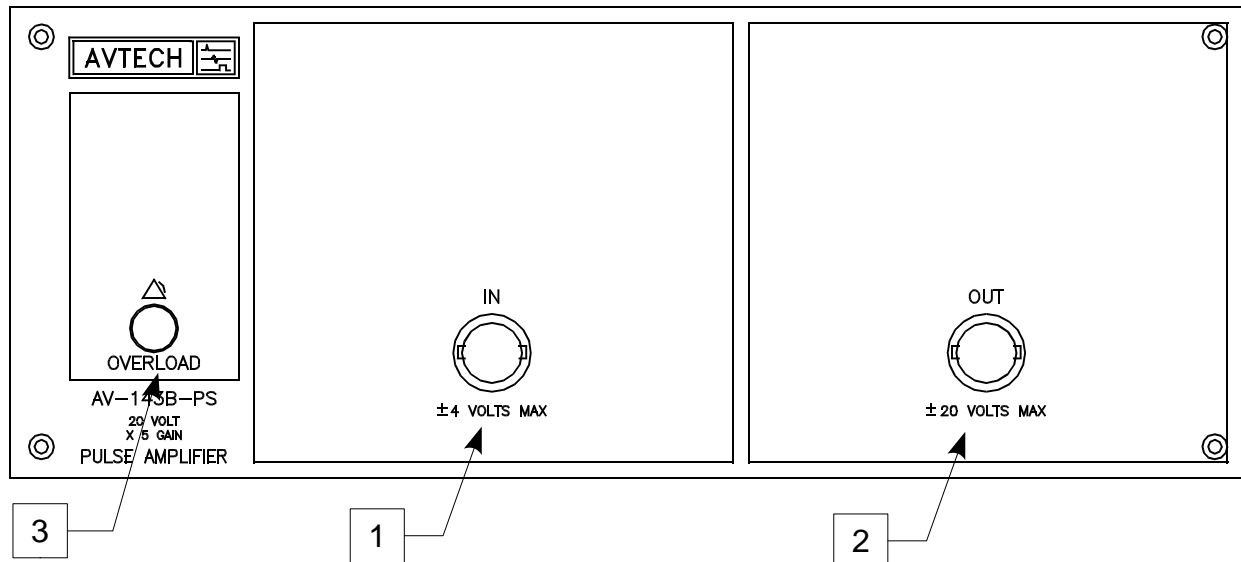

1. **IN CONNECTOR.** The input signal to be amplified is applied to this BNC connector. The input should not exceed $\pm 4V$. The input impedance is $1\text{ k}\Omega$.
2. **OUT CONNECTOR.** This BNC connector provides the main output signal. This output can supply up to $\pm 20V$ into a 50Ω (or greater) load. The output impedance is approximately $2\ \Omega$.
3. **OVERLOAD.** Units with a serial number higher than 5600 are protected by an automatic overload protective circuit, which controls the front panel overload light. If the unit is overloaded (by operating at an exceedingly high duty cycle or by operating into a short circuit), the protective circuit will turn the output of the instrument OFF and turn the indicator light ON. The light will stay ON (i.e. output OFF) for about 5 seconds after which the instrument will attempt to turn ON (i.e. light OFF) for about 1 second. If the overload condition persists, the instrument will turn OFF again (i.e. light ON) for another 5 seconds. If the overload condition has been removed, the instrument will turn on and resume normal operation. Overload conditions may be removed by:
 - 1) Removing output load short circuit (if any)
 - 2) Reducing the output amplitude
 - 3) Reducing the output duty cycle (or pulse width)

Note that the overload light may come on when the prime power is applied. The light will extinguish after a few seconds.

REAR PANEL CONTROLS

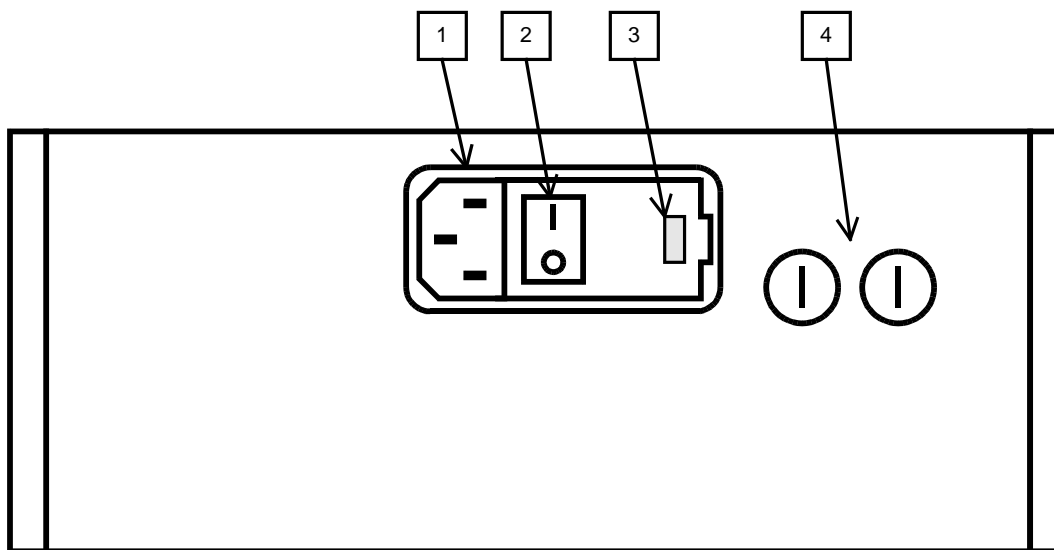

1. AC POWER INPUT. An IEC-320 three-pronged recessed male socket is provided on the back panel for AC power connection to the instrument. One end of the detachable power cord that is supplied with the instrument plugs into this socket.
2. POWER SWITCH. This is the main power switch. The instrument should be positioned so that the switch is accessible.
3. FUSE HOLDER / VOLTAGE SELECTOR. This red plastic module must be installed so that the marked voltage equals the AC line voltage. This module also contains two fuses that protect the AC inputs. Please see the “LINE VOLTAGE SELECTION” and “FUSES” sections of this manual for more information.
4. DC FUSES. These two fuses protect the internal DC power supplies. Please see the “FUSES” sections of this manual for more information.

GENERAL INFORMATION

BASIC OPERATION

This instrument is very straightforward to connect and operate. There are no adjustable controls used in normal operation. The input signal is connected to the "IN" connector, and the output signal is generated by the amplifier on the "OUT" connector.

The basic test arrangement is shown below:

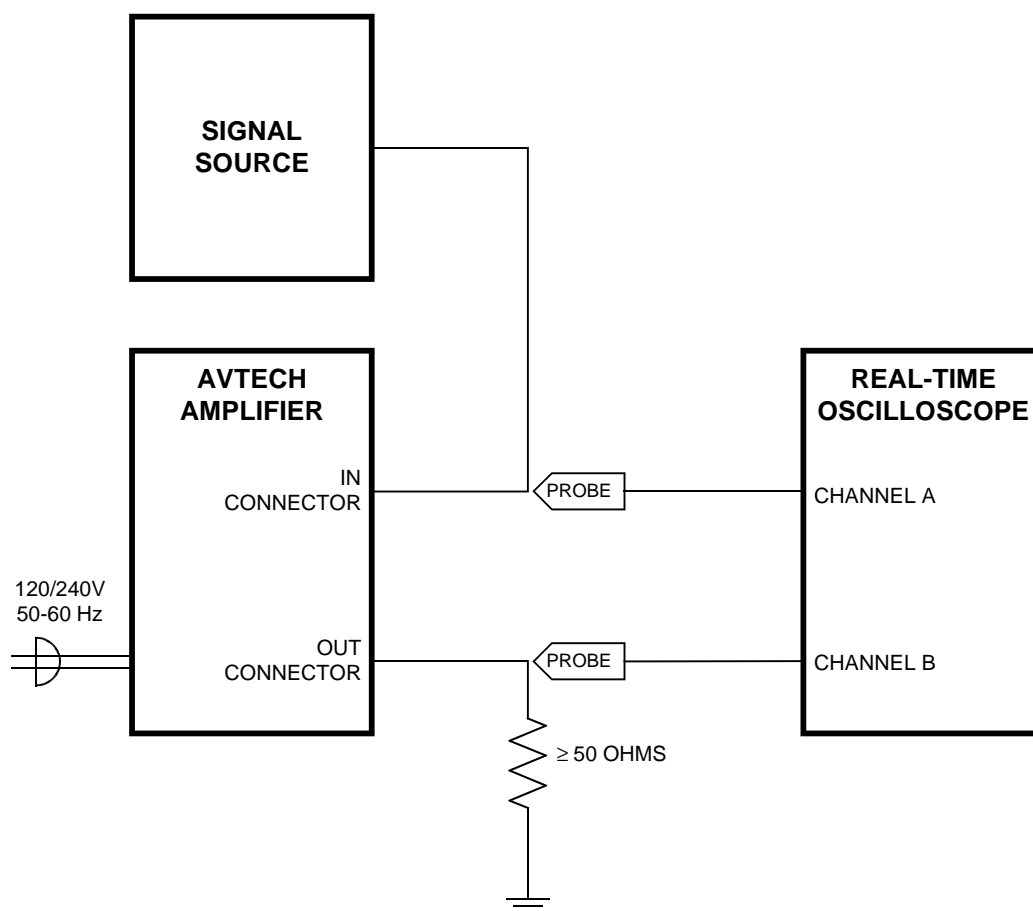

OPERATIONAL CHECK

To confirm the operation of the instrument, connect the amplifier as shown on page 9. Use a signal source capable of generating a 0 to +4V pulse, with rise and fall times of less than 10 ns, and a pulse width of approximately 500 ns. (The Avtech AV-1000-C pulse generator is suitable for this purpose).

Confirm that the oscilloscope properly displays the input signal. Then turn on the Avtech amplifier, and observe the output signal on the oscilloscope. The output amplitude should be approximately +20V, with rise and fall times of 50 ns (when measured between the 20% and 80% amplitude points of each edge).

The waveform below illustrates typical input and output waveforms. The upper waveform is the 0 to +4V input, and the lower waveform is the 0 to +20V output into a 50Ω load.

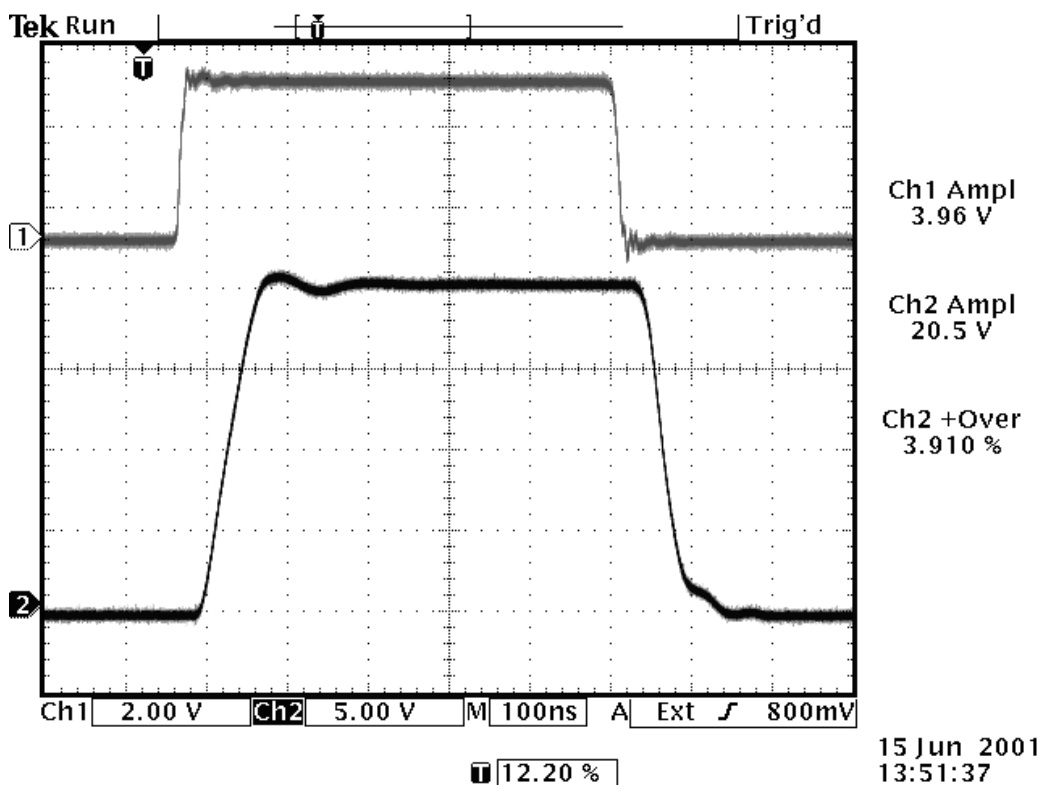

Note that if the rise and fall times of the input signal are longer than 10 ns, the output rise and fall times will increase correspondingly.

If additional assistance is required, contact:

Tel: (613) 226-5772, Fax: (613) 226-2802
Email: info@avtechpulse.com

USAGE PRECAUTIONS

The unit may be damaged if operated into a short circuit. Such failures are not covered by the warranty. The load impedance must be equal to or greater than 50 Ohms.

The input may be damaged if voltages much greater than $\pm 4V$ are applied. Such failures are not covered by the warranty.

Never apply an external voltage to the output, or the output may be damaged. Such failures are not covered by the warranty.

INTERNAL ADJUSTMENTS

There is an internal DC offset null trimpot inside the amplifier. If a small DC offset is observed on the output, turn off the instrument. Remove the four screws holding the top cover in place, and slide the cover towards the rear and off. Locate the blue circuit “-PG” module. A small brass screw should be visible on the top surface of the “-PG” module. Turn on the instrument, and rotate this screw until the offset is zero.

The offset was nulled to zero at the time of shipping.

MECHANICAL INFORMATION

TOP COVER REMOVAL

If necessary, the interior of the instrument may be accessed by removing the four Phillips screws on the top panel. With the four screws removed, the top cover may be slid back (and off).

Always disconnect the power cord before opening the instrument.

There are no user-repairable internal circuits. For repairs other than fuse replacement, please contact Avtech (info@avtechpulse.com) to arrange for the instrument to be returned to the factory for repair.



Caution: High voltages are present inside the instrument during normal operation. Do not operate the instrument with the cover removed.

RACK MOUNTING

A rack mounting kit is available. The -R5 rack mount kit may be installed after first removing the one Phillips screw on the side panel adjacent to the front handle.

ELECTROMAGNETIC INTERFERENCE

To prevent electromagnetic interference with other equipment, all used outputs should be connected to shielded 50 Ω loads using shielded 50 Ω coaxial cables. Unused outputs should be terminated with shielded 50 Ω BNC terminators or with shielded BNC dust caps, to prevent unintentional electromagnetic radiation. All cords and cables should be less than 3m in length.

MAINTENANCE

REGULAR MAINTENANCE

This instrument does not require any regular maintenance.

On occasion, one or more of the four rear-panel fuses may require replacement. All fuses can be accessed from the rear panel. See the “FUSES” section for details.

CLEANING

If desired, the interior of the instrument may be cleaned using compressed air to dislodge any accumulated dust. (See the “TOP COVER REMOVAL” section for instructions on accessing the interior.) No other cleaning is recommended.

PERFORMANCE CHECK SHEET